

POWER FACTOR

MOTOROLA

SOLUTIONS

APEC BOSTON 92

MOTOROLA



Jim Spangler

Application Engineer

Motorola Semiconductor

2300 N. Barrington Road

Hoffman Estates, Ill 60195

708-884-2573



OUTLINE

1. REVIEW OF MATH
2. TEST EQUIPMENT SET UP
3. IEC 555-2 SPECIFICATIONS
4. MC34161 AUTO SELECT and POWER FACTOR CORRECTION CIRCUIT
5. MC34261 POWER FACTOR CORRECTION INTEGRATED CIRCUIT
6. DESIGN EXAMPLE MC34261
7. PLACEMENT OF FILTER CAPACITOR



REASONS FOR POWER FACTOR

1. Reduce reactive power.
2. Reduce harmonic currents.
3. Reduce current in the neutral of 4 wire system.
4. Reduce fire hazard in office building modular furniture.
5. Maintain the same wire size for all wires in a 4 wire system in 3Ø building systems.
6. Build products which pass the newer government specifications.
 - A. IEC 555-2 A, B, C, D
 - B. ANSI
 - C. CSA



Three \emptyset current in the neutral

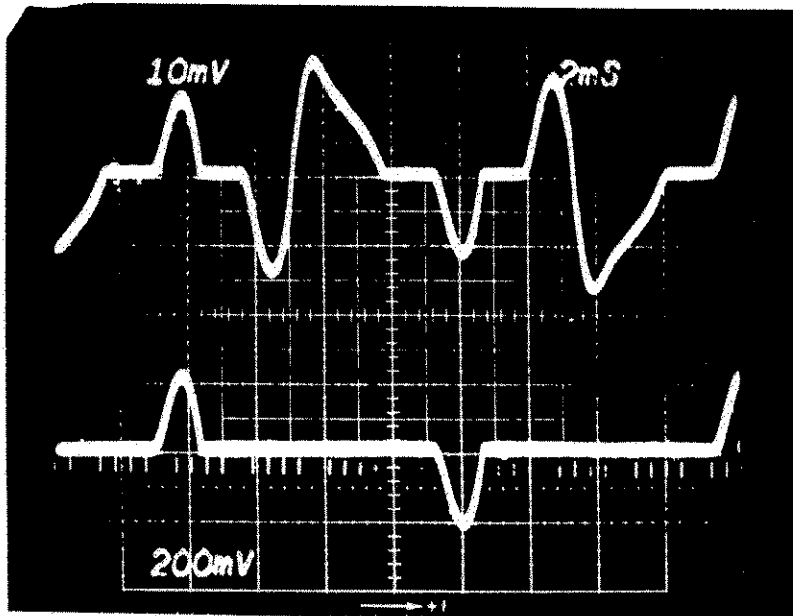
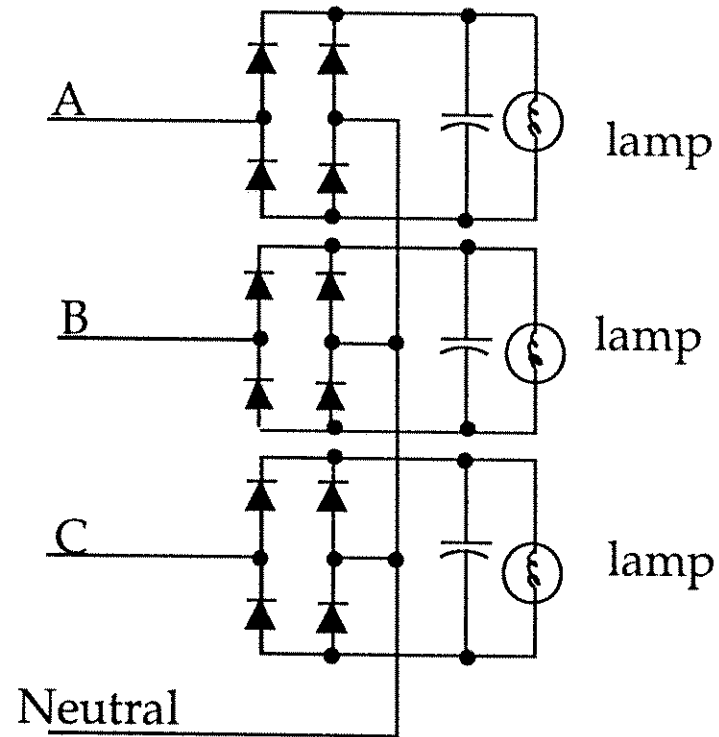

Photo of current in neutral



Schematic



Power Factor Math

$$P_{\text{Power}} = V_{\text{rms}} I_{\text{rms}} \cos \phi$$

$$P_{\text{Power}} = V_{\text{rms}} I_{\text{rms}} \frac{I_{1 \text{ rms}}}{I_{\text{rms}}} \cos \phi$$

$$P_{\text{Power}} = S k_d k_{\phi}$$

$$S = V_{\text{rms}} I_{\text{rms}} \quad \text{Apparent Power}$$

$$k_d = \frac{I_{1 \text{ rms}}}{I_{\text{rms total}}} \quad \text{Distortion Factor}$$

$$k_{\phi} = \cos \phi_1 \quad \text{Displacement Factor}$$

Assumption: V input rms is a pure sine wave without distortion



INSTRUMENTATION

1. Measuring these parameters

k_d Distortion

k_ϕ Displacement

2. Spectrum Analyzer (Amplitudes)

$$V_{\text{rms Total}} = \sqrt{V_{\text{DC}}^2 + V_{1\text{ rms}}^2 + V_{2\text{ rms}}^2 + V_{3\text{ rms}}^2 \dots + V_n^2}$$

$$I_{\text{rms Total}} = \sqrt{I_{\text{DC}}^2 + I_{1\text{ rms}}^2 + I_{2\text{ rms}}^2 + I_{3\text{ rms}}^2 \dots + I_n^2}$$

3. Distortion (Distortion Analyzer)

Total Harmonic Distortion (THD)

$$\text{Total Harmonic Distortion} = \frac{I_{\text{not fundamental}}}{I_{\text{rms Total}}}$$

$$\text{Harmonic Distortion} = \sqrt{\frac{I_{\text{rms Total}}^2 - I_{1\text{ rms}}^2}{I_{1\text{ rms}}^2}}$$



4.
$$k_d = \sqrt{\frac{1}{1 + (\text{THD})^2}}$$

5. **Displacement Factor**

k_ϕ = Displacement factor calculated*

* unless measured by the following

Power Analyzers

Voltech 508 - 881 -7329

PM 1000 (harmonics DC to 13 no phase)

PM 1200 and PM 3000

Zitron 619 - 458 - 9852

2501 / 2502 / 2503



Power with AC Line Distortion

$$P_{\text{power}} = V_{\text{DC}}I_{\text{DC}} + \sum_{n=1}^{\infty} V_{n \text{ rms}}I_{n \text{ rms}} \cos \phi$$
$$\phi_n = \angle V_{n \text{ rms}} - \angle I_{n \text{ rms}}$$

1. AC line distortion measured at 5 %
2. Distortion was 3 rd order due to transformer
2. Power 60 Hz was greater than Total Power
3. Power 180 Hz was negative



IEC 555-2

CLASS A Motors

CLASS B Portable equipment

**CLASS C Lighting equipment (ballast for lamps)
Tightest specifications**

**CLASS D Power Supplies, ect.
Waveform guide line.**



IEC 555-2 FLOW CHART

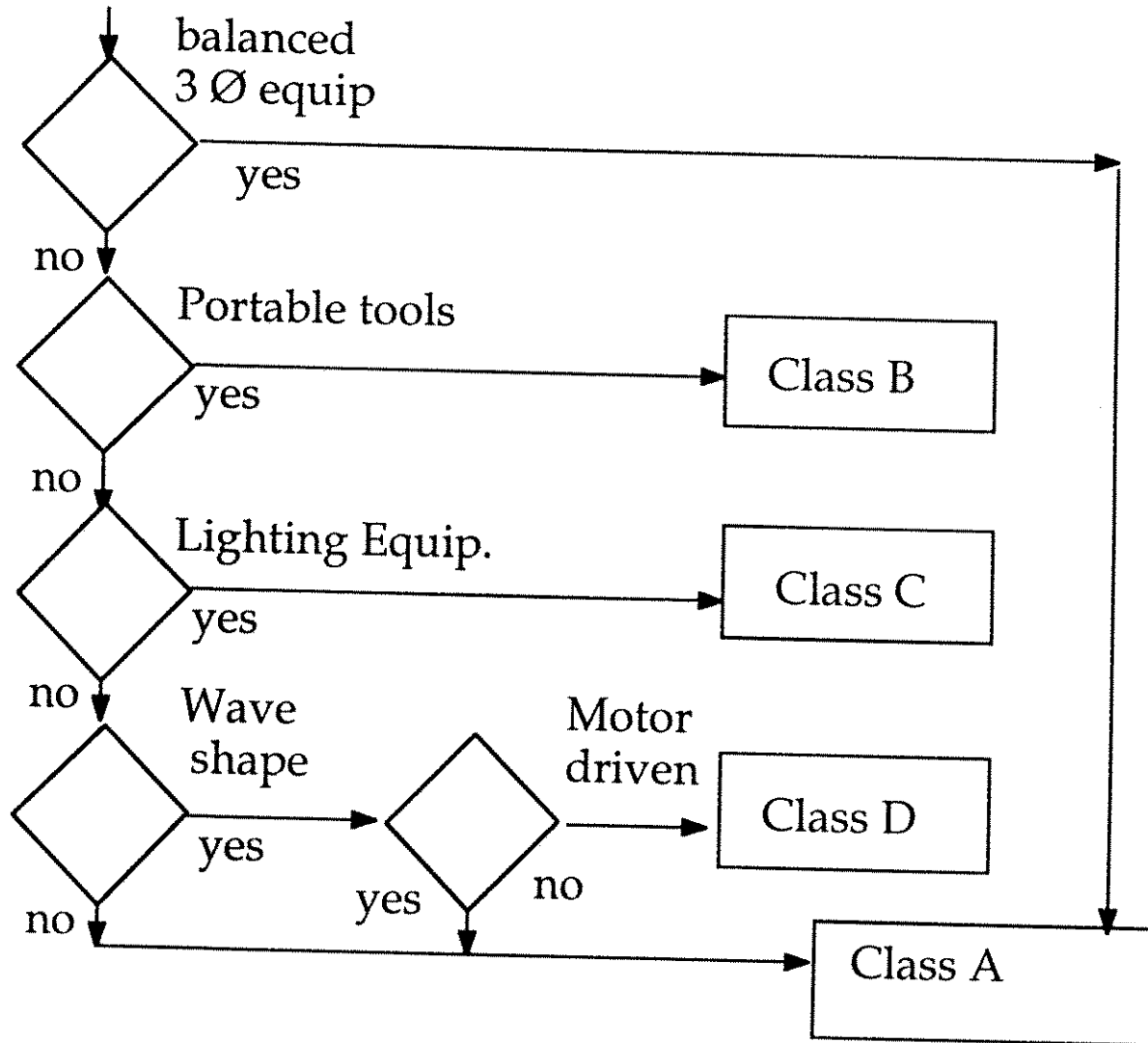

IEC 555-2 CLASS D

harmonic	relative limits <u>mA / W</u>	absolute limits <u>Amps</u>
2	1.0	0.30
3	3.6	1.08
4	0.5	0.15
5	2.0	0.60
7	1.5	0.45
9	1.0	0.30
$11 \leq n \leq 39$	$0.6 * (11/n)$	$0.18* (11/n)$

Special waveform scheduled to be eliminated



Test Equipment Set Up

1. Measurements not accurate on non-stiff line
2. AC line distortion caused by
 - A. Isolation transformer
 - B. Variac
3. Safety and care
 - A. Differential voltage measurements
 - B. Current probes
 1. Hall Effect
 2. Current Transducers



Test Equipment Set Up

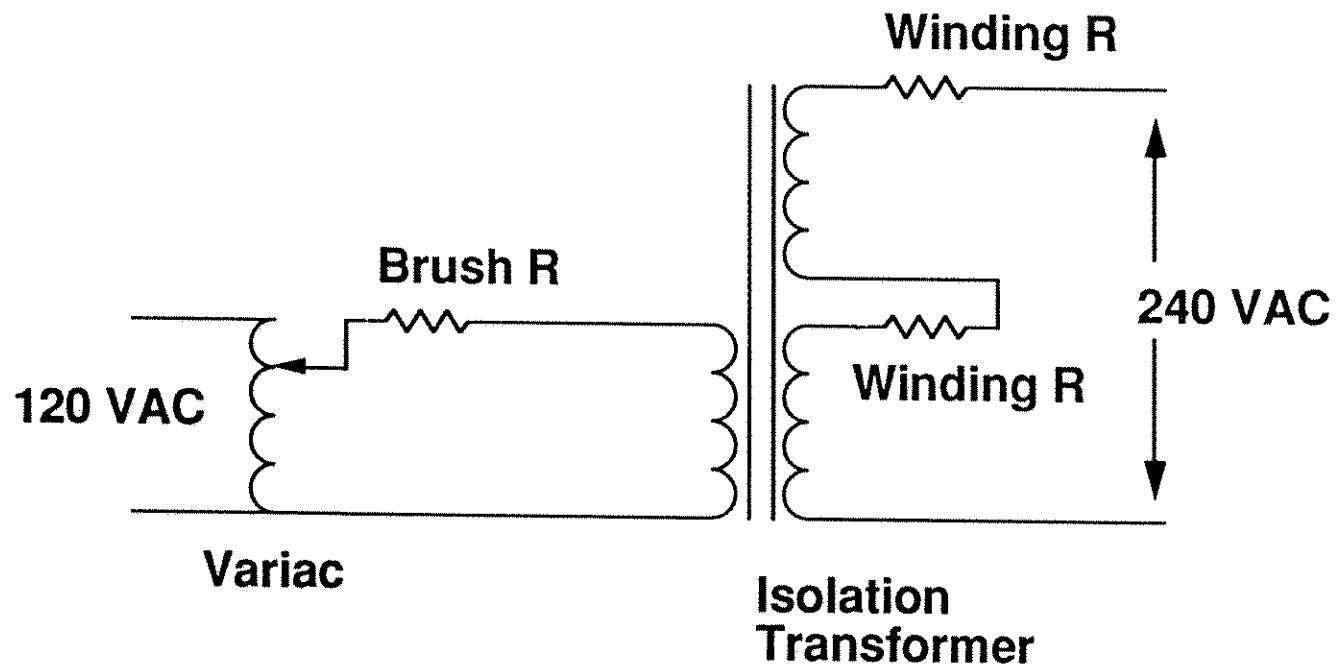

Schematic



Test Equipment Set Up

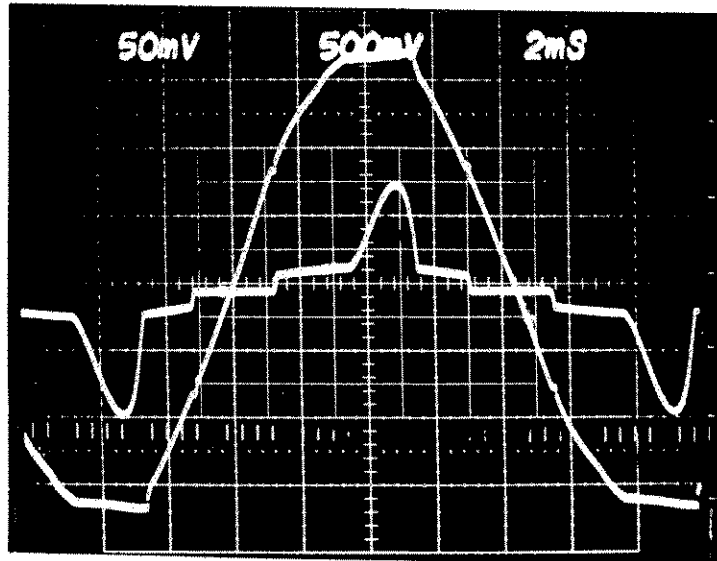

Variac - Isolated

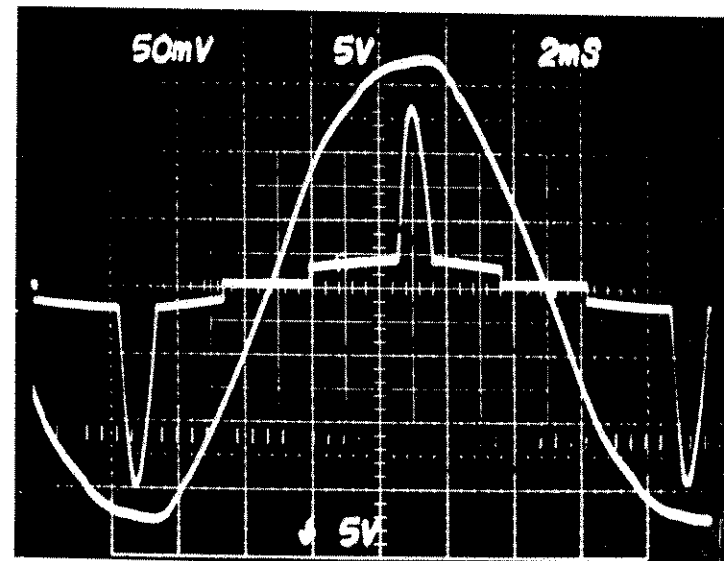

Non - Isolated

EFFECT



MC 34161

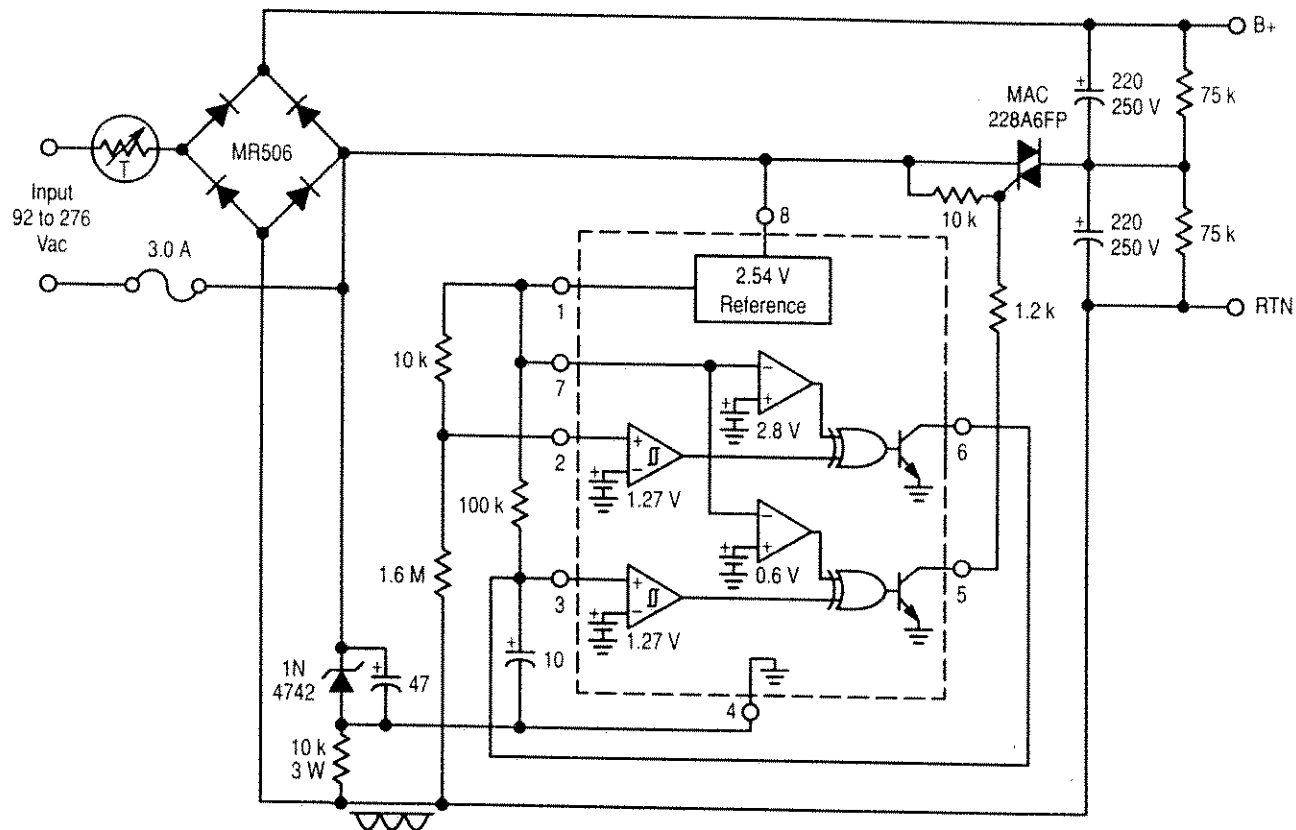

The above circuit shows the MC34161 configured as an automatic line voltage selector. The IC controls the triac, enabling the circuit to function as a fullwave voltage doubler or a fullwave bridge. Channel 1 senses the negative half cycles of the AC line voltage. If the line voltage is less than 150 V, the circuit will switch from bridge mode to voltage doubling mode after a preset time delay. The delay is controlled by the 100 kΩ resistor and the 10 μF capacitor. If the line voltage is greater than 150 V, the circuit will immediately return to fullwave bridge mode.

Auto Select 120 / (220/240) Data Sheet Figure 25



MC 34161

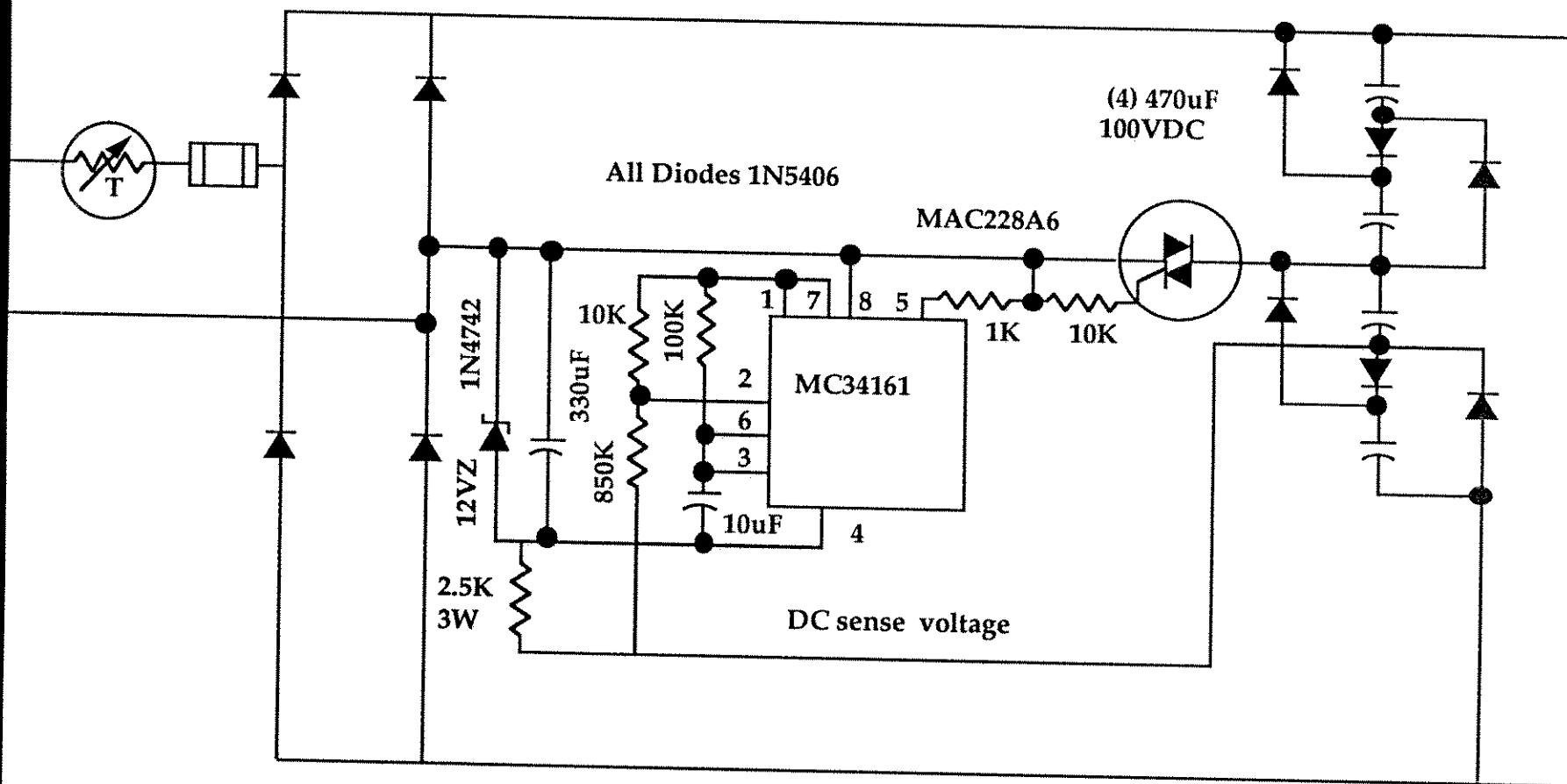

Auto Select Power Factor



MC34161

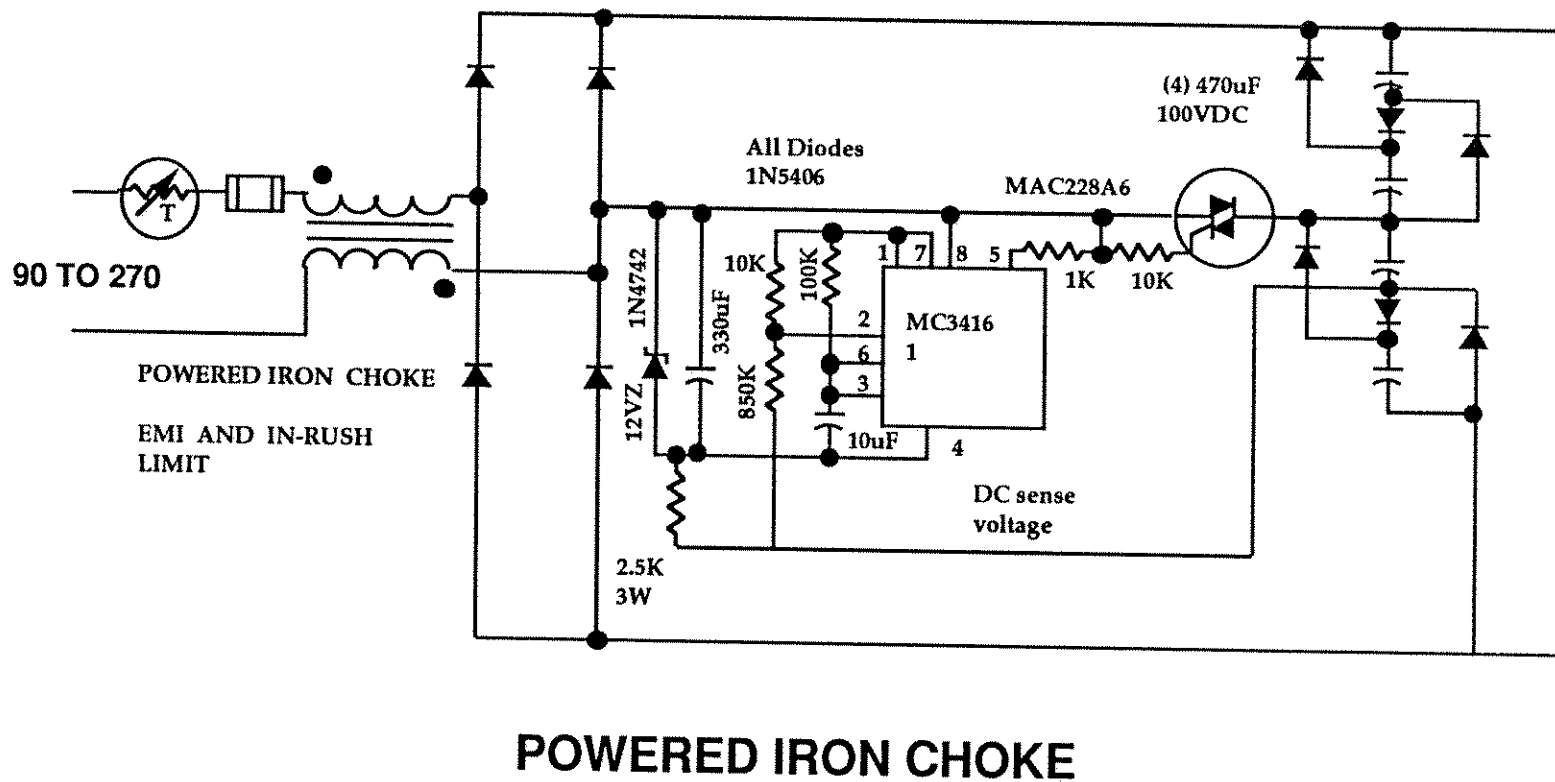

Motorola parts

1. (1) MC 34161
2. (10) 1N4006 or 1N5406
3. (1) MAC228 A6 FP (Fully isolated, UL approved)
4. (1) 1N4742 12 volt zener diode



Valley Fill Data

<u>Volts</u>	<u>amps</u>	<u>watts</u>	<u>_pf</u>	<u>3rd.</u>	<u>5th</u>	<u>7th</u>	<u>9th</u>	
120	1.42	140.7	.816	.56	.348	.351	.154	Stiff line
limits Class D				.504	.280	.210	.140	
120	0.91	94.0	.854	.345	.232	.145	.095	Choke
limits Class D				.338	.188	.141	.094	
243	0.615	137.8	.922	.143	.028	.09	.06	Stiff line
limits Class D				.496	.276	.207	.138	
244.9	0.896	201.2	.920	.212	.052	.138	.100	Stiff line
limits Class D				.723	.402	.301	.201	



MC 34161 Voltage and Current Waveform

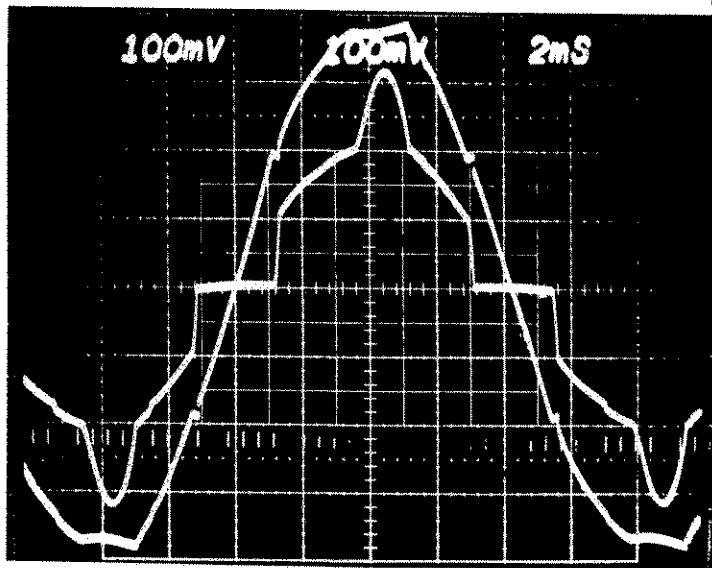

224.2 Volts

1.776 Amps

383.3 Watts

0.961 Power Factor



Adjustments Due to Valley Fill

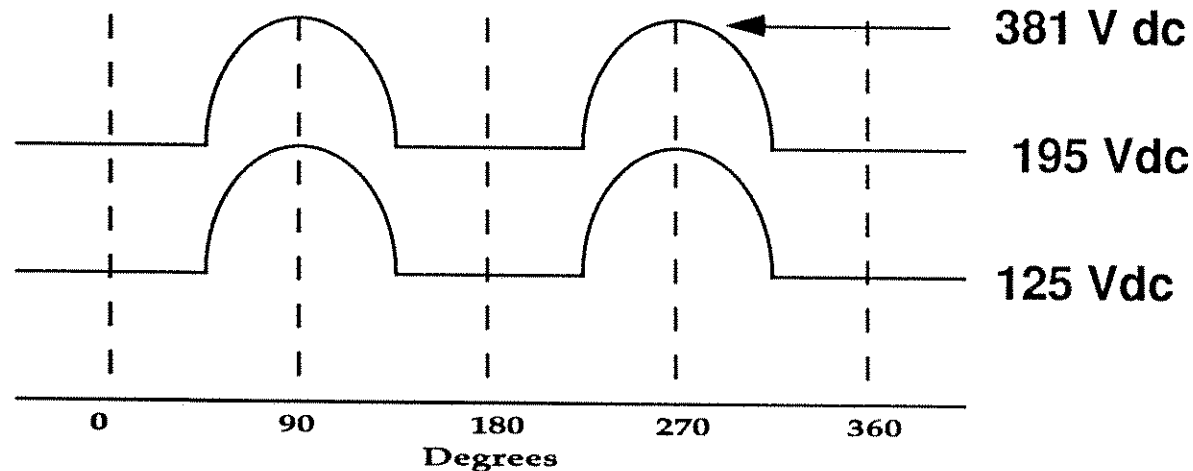

1. Input voltage range
Min voltage 125 Vdc (90 Volts ac or 165 Volts ac)
Max. Voltage 381 Vdc (135 Volts ac or 270 Volts ac)
2. Design limits are 3 :1 ($381 / 125$) = 3.05
3. Cross over is at 150 Vac varies with tolerances
4. Normal operation requires 2 :1 ($381 / 195$)



FLYBACK

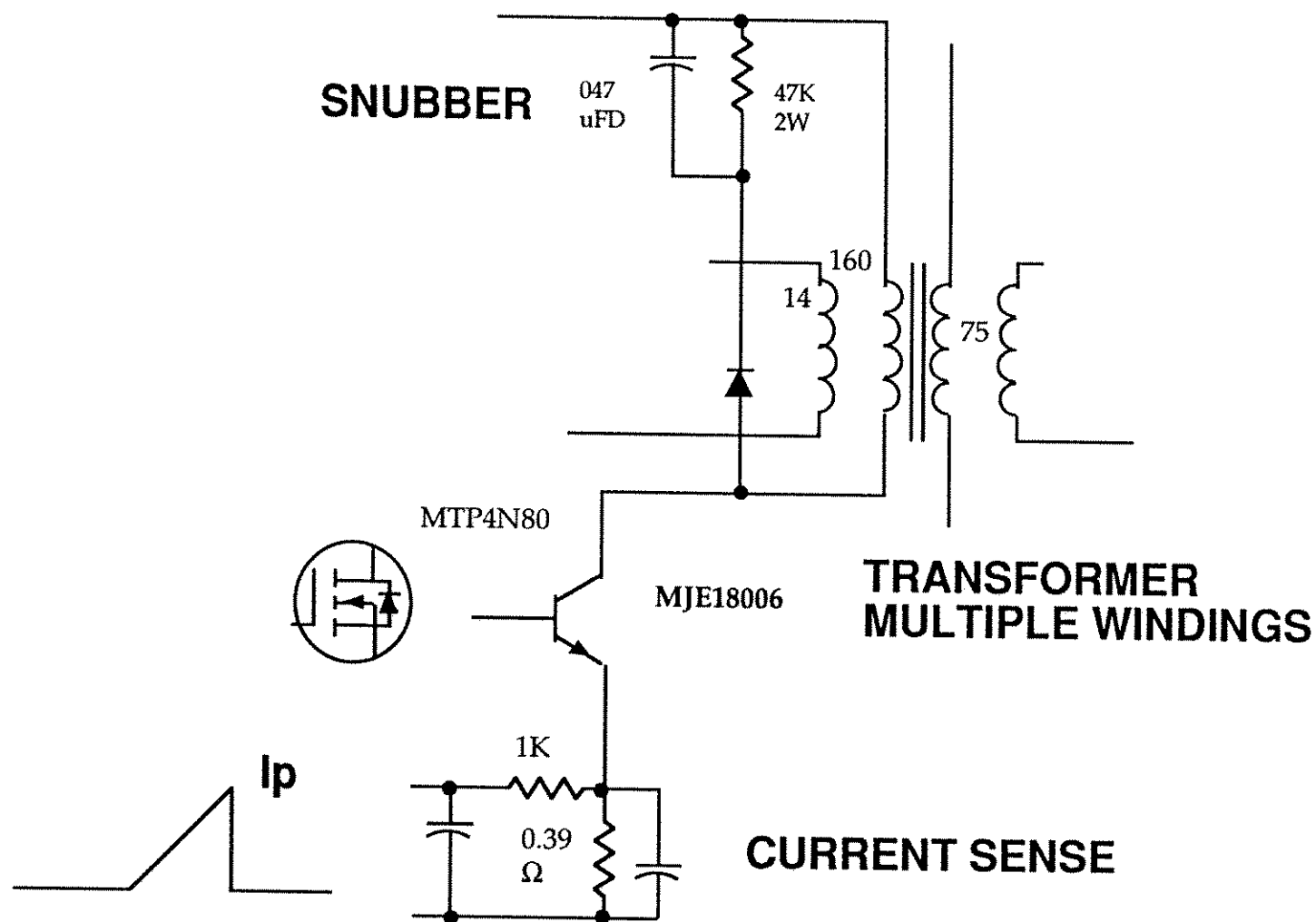

Flyback Design

$$I_{\text{peak}} = \frac{2 * W_{\text{atts}}}{\delta_{\text{max}} * V_{\text{dc min.}}}$$

$$3.55 \text{ Amps} = \frac{2 \times 100}{0.45 \times 125}$$

$$5.33 \text{ Amps} = \frac{2 \times 150}{0.45 \times 125}$$

$$7.11 \text{ Amps} = \frac{2 \times 200}{0.45 \times 125}$$

$$K = \frac{V_{\text{DC max.}}}{V_{\text{DC min.}}}$$

$$K = \frac{381}{125} = 3.048$$

$$\delta_{\text{min.}} = \frac{\delta_{\text{max.}}}{(1 - \delta_{\text{max.}}) K + \delta_{\text{max.}}}$$

$$0.211 = \frac{0.45}{(1 - 0.45) 3.048 + 0.45}$$



MOTOROLA TRANSISTORS SINGLE ENDED FLYBACK

<u>PART NUMBER</u>	<u>AMPS</u>	<u>Vceo</u>	<u>Vces</u>
BUL44	2	400	700
MJE 18002	2	450	1000
BUL45	5	400	700
MJE 18004	5	450	1000
BUL146	8	400	700
MJE 18006	8	450	1000
BUL147	10	400	700
MJE 18008	10	450	1000
MJW 18010	15	450	1000



MOTOROLA POWER FETS FOR SINGLE ENDED OPERATION

<u>DEVICE</u>	<u>AMPS</u>	<u>VOLTS</u>	<u>PACKAGE</u>
MTP4N80E	4	800	TO-220
MTW4N80E	4	800	TO-247
MTW7N80E	7	800	TO-247



DUAL POWER FET CONVERTER

<u>DEVICE</u>	<u>AMPS</u>	<u>VOLTS</u>	<u>PACKAGE</u>
MTP3N50E	3	500	TO-220
MTP4N50E	4	500	TO-220
MTP8N50E	8	500	TO-220
MTW8N50E	8	500	TO-247
MTW14N50E	14	500	TO-247
MTW20N50E	20	500	TO-247



UC3843 CONSTANT FREQUENCY APEC 91 and IAS 91

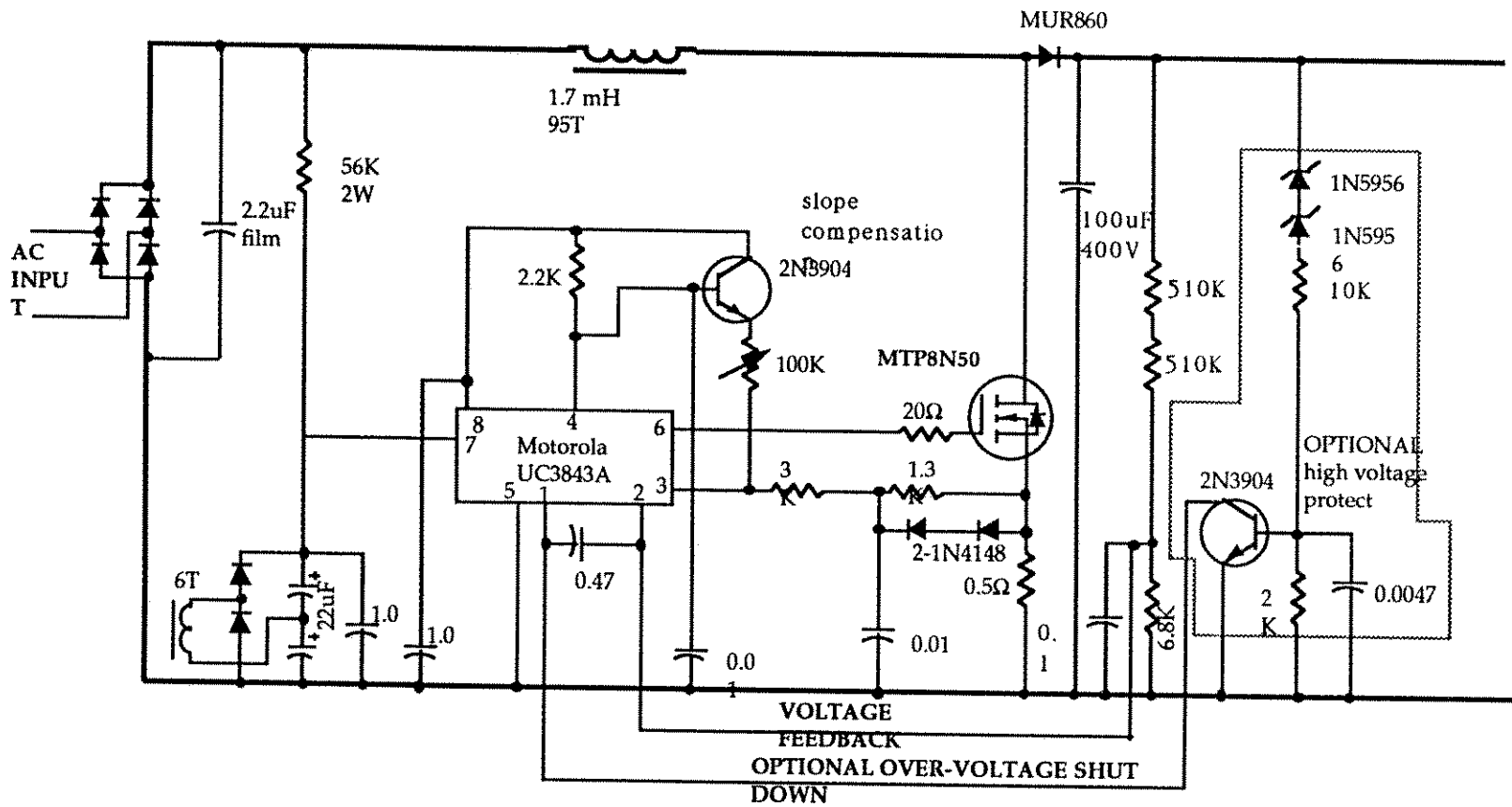

CONTINUOUS DUTY BOOST

Boost Converter Power Factor Measurements

340 VOLT BUS

volts	amps	watts	pwr fact	fund	these are in percent					V out dc bus	T.H.D. %	T.H.D. sum of sq.
					2nd	3rd	5th	7th	9th			
181.1	2.410	422.0	0.970	2.356	0.12	17.23	10.00	5.72	2.96	322.0	21.53	20.94
190.6	2.419	445.3	0.970	2.364	0.02	17.61	9.93	5.86	3.25	328.8	21.70	21.30
199.6	2.417	469.1	0.968	2.360	0.09	18.14	9.80	6.03	3.49	338.8	22.11	21.76
210.0	2.267	466.0	0.971	2.223	0.09	17.09	9.09	6.00	3.80	338.9	19.99	20.62
220.3	2.156	463.0	0.974	2.109	0.06	15.86	8.33	5.73	3.83	338.9	21.23	19.19
230.9	2.038	460.5	0.978	2.005	0.10	14.05	7.08	5.32	3.61	338.9	18.22	17.00
<u>IEC SPECIFICATIONS</u>					<u>2.00</u>	<u>27.00</u>	<u>10.00</u>	<u>7.00</u>	<u>5.00</u>			<u>32.00</u>

385 VOLT BUS

volts	amps	watts	pwr fact	fund	these are in percent					V out dc bus	T.H.D. %	T.H.D. sum of sq.
					2nd	3rd	5th	7th	9th			
182.3	1.950	348.0	0.972	1.907	0.05	16.19	10.19	5.85	2.96	384.3	21.36	20.22
190.0	1.897	350.9	0.973	1.864	0.06	15.63	10.00	5.81	3.18	384.1	18.90	19.70
199.4	1.795	349.8	0.976	1.769	0.08	14.00	9.27	5.80	3.35	384.0	17.21	18.08
211.1	1.684	348.8	0.980	1.663	0.03	11.53	8.27	5.40	3.36	384.0	15.94	15.55
220.2	1.603	348.1	0.982	1.583	0.16	9.26	7.28	4.83	3.00	383.8	16.03	13.08
231.0	1.530	347.2	0.985	1.515	0.17	6.94	6.25	4.28	2.74	383.7	13.91	10.63
240.6	1.463	347.1	0.986	1.459	0.19	4.58	5.22	3.65	2.26	383.6	7.41	8.17
<u>IEC SPECIFICATIONS</u>					<u>2.00</u>	<u>27.00</u>	<u>10.00</u>	<u>7.00</u>	<u>5.00</u>			<u>32.00</u>

400 VOLT BUS

volts	amps	watts	pwr fact	fund	these are in percent					V out dc bus	T.H.D. %	T.H.D. sum of sq.
					2nd	3rd	5th	7th	9th			
180.0	2.163	377.8	0.966	2.119	0.16	18.67	10.88	5.61	2.45	397.8	20.48	22.46
190.0	2.049	376.6	0.969	2.001	0.13	17.57	10.62	5.90	2.93	397.5	22.03	21.56
200.6	1.915	374.1	0.973	1.874	0.06	15.95	9.95	6.02	3.38	397.5	21.03	20.03
210.8	1.810	372.2	0.976	1.780	0.02	14.40	9.18	5.82	3.57	397.4	18.44	18.39
221.1	1.710	371.2	0.978	1.689	0.09	12.18	8.24	5.38	3.53	397.3	15.82	16.05
229.6	1.637	370.1	0.981	1.622	0.07	10.64	7.45	5.01	3.46	397.3	13.63	14.35
239.6	1.563	369.0	0.983	1.553	0.19	8.47	6.40	4.47	3.00	397.4	11.37	11.90
250.0	1.500	369.00	0.984	1.490	0.24	6.43	5.36	3.82	2.64	397.4	11.61	9.58
<u>IEC SPECIFICATIONS</u>					<u>2.00</u>	<u>27.00</u>	<u>10.00</u>	<u>7.00</u>	<u>5.00</u>			<u>32.00</u>



PARTS LIST

	<u>QT.</u>	<u>PART NO</u>	<u>DESCRIPTION</u>
1.	4	1N5406	DIODES
2.	1	MUR860	ULTRA FAST DIODE
3.	1	MTP8N50E	POWER FET
4.	2	1N5956	200 V 1.5 WATT ZENER
5.	2	2N3904	SS NPN TRANSISTORS
6.	1	UC3843A/B	PWM CONTROL IC



**POWER FACTOR
CORRECTION
INTEGRATED CIRCUIT**

MC 34261

APEC BOSTON 92

MOTOROLA



MC34261 FEATURES

1. Internal start up
2. One quadrant Multiply
3. Zero Current Detect
4. 2% Internal reference trimmed (TL431)
5. Totem pole putput (Direct Drive Power Fets)
6. Low start up current
7. Pin out SG 3561
8. Functional equilvelant to TDA 4817



MC 34261 BOOST CONVERTER

Figure 15. 80 W Power Factor Controller

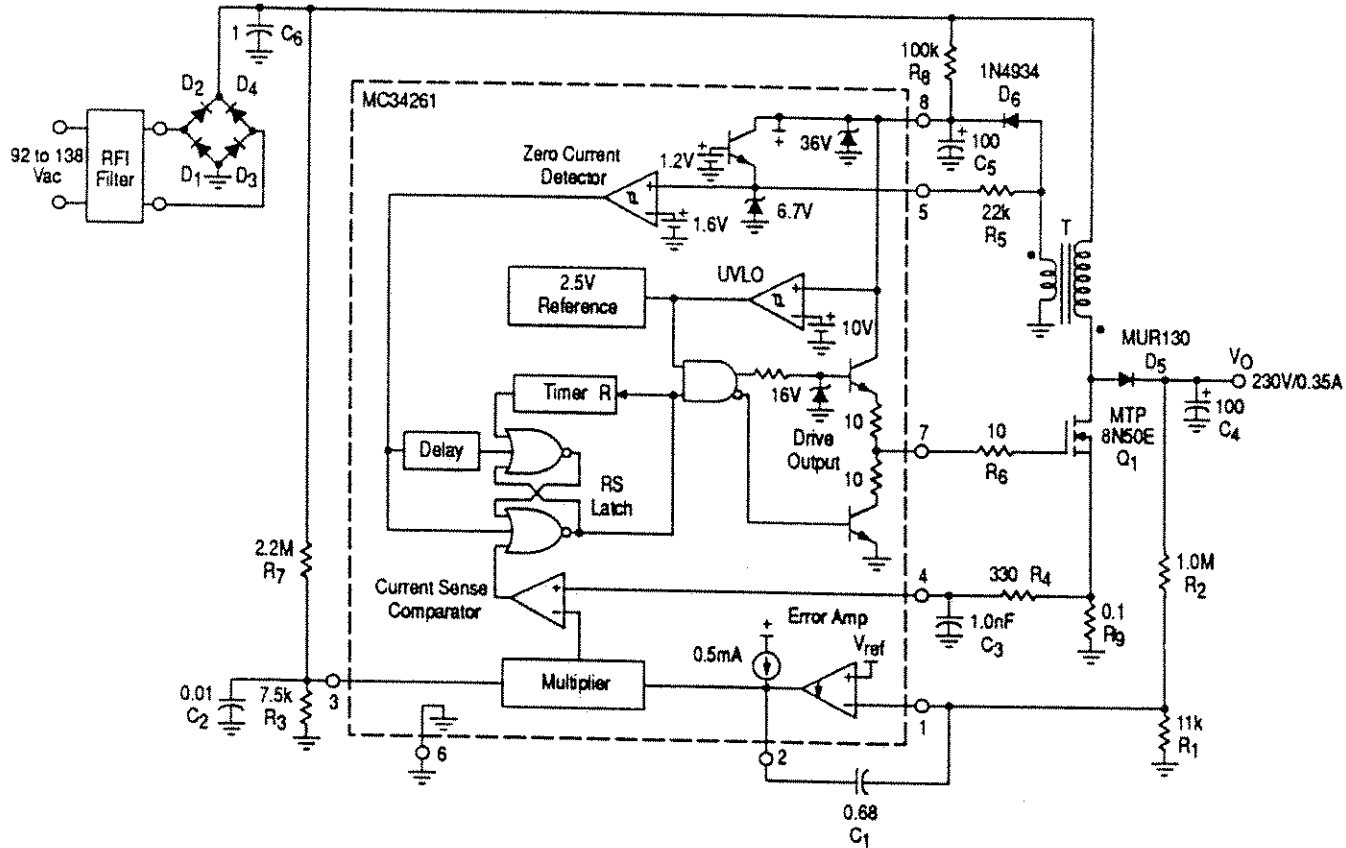

MC 34261

DISCONTINUOUS MODE ADVANTAGES

1. SMALL INDUCTOR
2. EASY TO DESIGN
3. NO REVERSE RECOVERY DIODE
4. NO POWER FET STRESS DUE TO DIODE REVERSE RECOVERY
5. MORE COMMERCIAL IC's AVAILABLE

CONTINUOUS MODE ADVANTAGES

1. SMALLER EMI FILTER
2. LOWER PEAK CURRENT
3. LESS STRESS ON THE OUTPUT ELECTROLYTIC CAPACITOR



MC 34261 DESIGN

DESIGNER MUST KNOW

1. WATTAGE
2. LOWEST FREQUENCY DESIRED
3. INPUT SUPPLY VOLTAGE
4. CHOOSE A DC OUTPUT VOLTAGE THAT IS 25 TO 50 VOLTS BEYOND THE MAX. PEAK AC LINE



MC34261 DISCONTINUOUS MODE

$$R = \frac{V_{DC \text{ Output}}}{\sqrt{2} \times V_{rms \text{ min}}} - 1$$

$$\Delta t_1 = \frac{R}{F_{\text{frequency}}(1 + R)}$$

Δt_1 on time which remains constant
for each wattage and ac line voltage

$$\Delta t_1 = \frac{2 \times L \times W}{\eta \times V_{rms \text{ min.}}^2}$$



INDUCTOR DESIGN

$$L = \frac{\Delta t_1 \times V_{\text{rms min.}}^2 \times \eta}{2 \times W}$$

Using Faraday's Law the Choke can now be designed

$$\Delta t_1 \times V_{\text{rms min.}} = N \times A_e \times \Delta B$$



CURRENT RATINGS

$$I_{\text{Peak max.}} = \frac{\sqrt{2} \times 2 \times W}{\eta \times V_{\text{rms min.}}}$$

The power MOSFET and the rectifier must be able to handle the peak current.

This also defines the current the inductor must handle.



Current vs Input Voltage

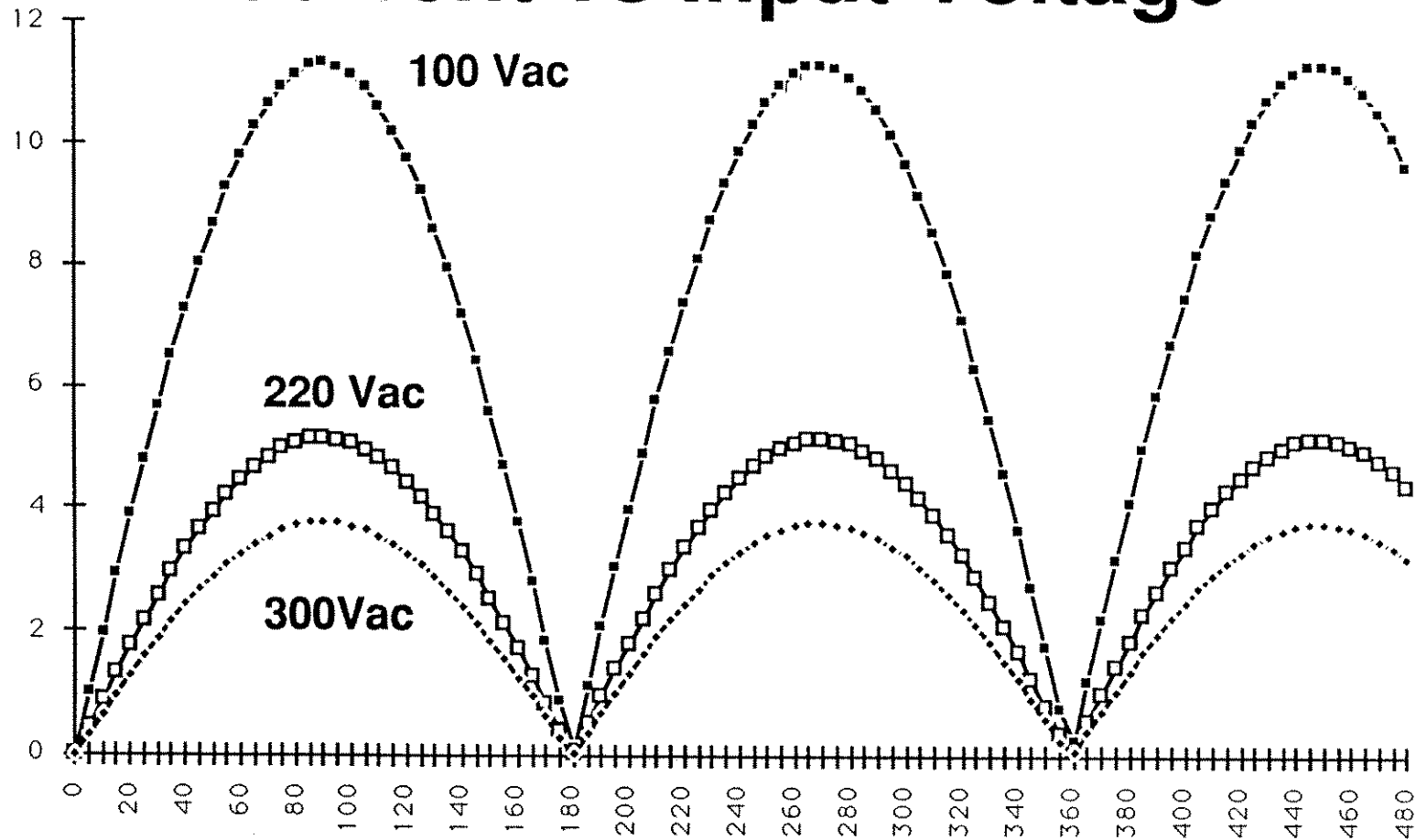

Frequency vs Input Voltage

V dc output = 500 V
Watts = 400

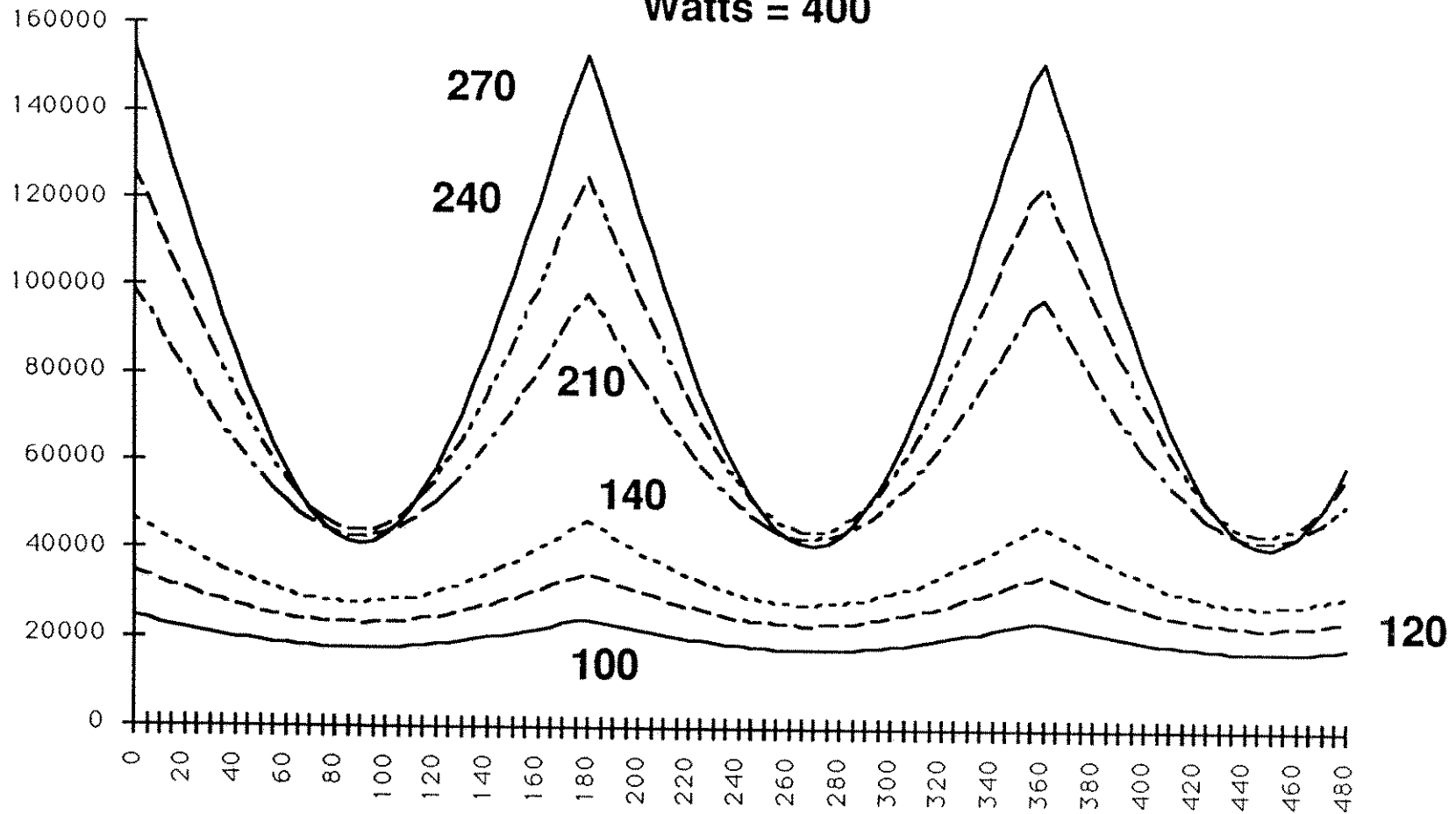

LIGHT LOAD DISTORTION

1.0 μF capacitor does not totally discharge under light loads.
Power factor and EMI trade-offs for THD light loads.
True for both continuous duty and discontinuous duty

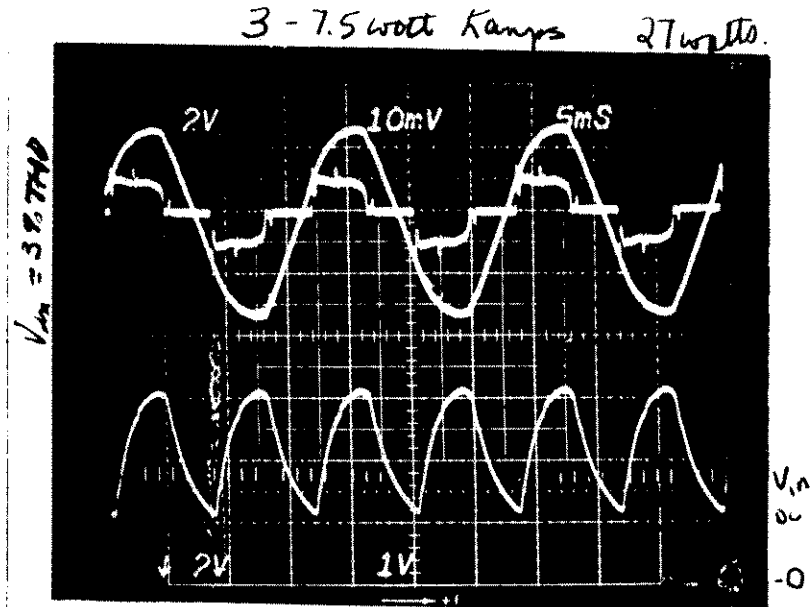
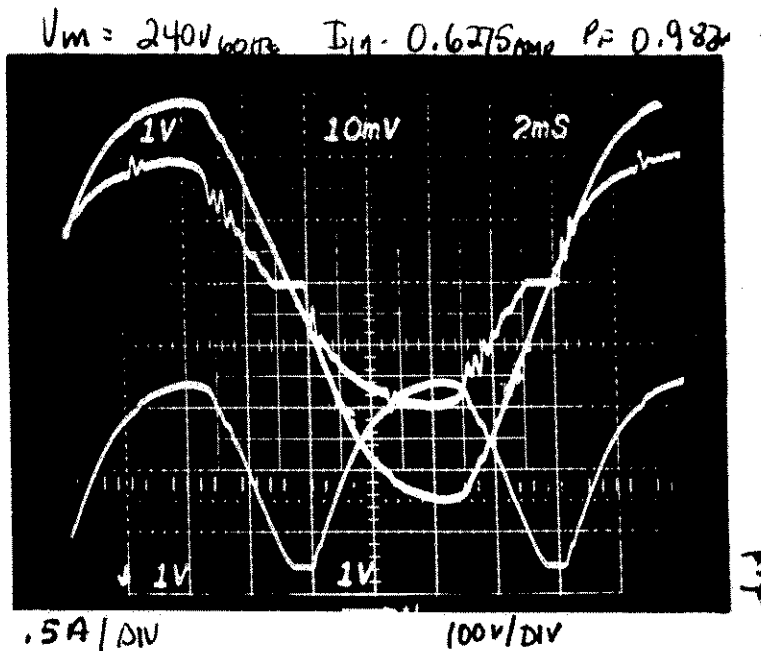

Power Factor Controller Test Data

V _{rms}	P _{in}	PF	AC Line Input					DC Output				
			Current Harmonic Distortion (%)					V _{O(p-p)}	V _O	I _O	P _O	η(%)
			THD	2	3	5	7					
90	85.6	-0.998	2.4	0.11	0.52	1.3	0.67	10.0	230	0.350	80.5	94.0
100	85.1	-0.997	5.0	0.13	1.7	2.4	1.4	10.1	230	0.350	80.5	94.6
110	84.8	-0.997	5.3	0.12	2.5	2.6	1.5	10.2	230	0.350	80.5	94.9
120	84.5	-0.997	5.8	0.12	3.2	2.7	1.4	10.2	230	0.350	80.5	95.3
130	84.2	-0.996	6.6	0.12	4.0	2.8	1.5	10.2	230	0.350	80.5	95.6
138	84.1	-0.995	7.2	0.13	4.5	3.0	1.6	10.2	230	0.350	80.5	95.7

This data was taken with the test set-up shown in Figure 17.

T = Coilcraft N2881-A

Primary: 62 turns of # 22 AWG

Secondary: 5 turns of # 22 AWG

Core: Coilcraft PT2510, EE 25

Gap: 0.072" total for a primary inductance of 320 μH

Heatsink = AAVID Engineering Inc. 5903B, or 5930B

V _{rms}	P _{in}	PF	AC Line Input					DC Output				
			Current Harmonic Distortion (%)					V _{O(p-p)}	V _O	I _O	P _O	η(%)
			THD	2	3	5	7					
90	187.5	-0.998	2.0	0.10	0.98	0.90	0.78	8.0	400.7	0.436	174.7	93.2
120	184.6	-0.997	1.8	0.09	1.3	1.3	0.93	8.0	400.7	0.436	174.7	94.6
138	183.6	-0.997	2.3	0.05	1.6	1.5	1.0	8.0	400.7	0.436	174.7	95.2
180	181.0	-0.995	4.3	0.16	2.5	2.0	1.2	8.0	400.6	0.436	174.7	95.6
240	179.3	-0.993	6.0	0.08	3.7	2.7	1.4	8.0	400.6	0.436	174.7	97.4
268	178.6	-0.992	6.7	0.16	2.8	3.7	1.7	8.0	400.6	0.436	174.7	97.8

This data was taken with the test set-up shown in Figure 17.

T = Coilcraft N2880-A

Primary: 78 turns of # 16 AWG

Secondary: 6 turns of # 18 AWG

Core: Coilcraft PT4215, EE 42-15

Gap: 0.104" total for a primary inductance of 870 μH

Heatsink = AAVID Engineering Inc. 5903B



TEST CIRCUIT

Figure 17. Power Factor Test Set-Up

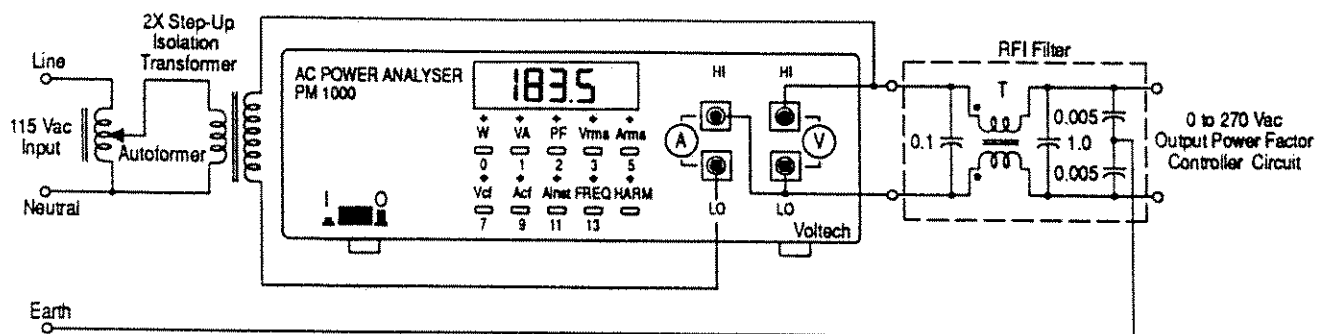

An RFI filter is required for best performance when connecting the preconverter directly to the AC line. Commercially available two stage filters such as the Delta Electronics 03DPCG5 work excellent. The simple single stage test filter shown above can easily be constructed with a common mode transformer. Transformer (T) is a Coilcraft CMT3-28-2 with 28 mH minimum inductance and a 2.0 A maximum current rating.



PARTS

RECTIFIERS

1N4006	1 AMP 600 VOLT
1N5406	3 AMP 600 VOLT
MR756	6 AMP 600 VOLT

MUR160	1 AMP 600 VOLT
MUR460	4 AMP 600 VOLT
MUR860	8 AMP 600 VOLT

ZENER

1N5281A	200 V 0.5 WATT ZENER
1N5956A	200 V 0.5 WATT ZENER



TMOS FOR POWER FACTOR

<u>DEVICE</u>	<u>CURRENT</u>	<u>VOLTAGE</u>	<u>PK</u>
MTP10N25	10	250	TO-220
MTW15N25E	15	250	TO-247
MTP3N50E	3	500	TO-220
MTP4N50E	4	500	TO-220
MTP8N50E	8	500	TO-220
MTW8N50E	8	500	TO-247
MTW14N50E	14	500	TO-247
MTW20N50E	20	500	TO-247
MTW6N60E	6	600	TO-247
MTW8N60E	8	600	TO-247



OTHER ITEMS

1. **FIXED FREQUENCY**
 - A. **DISCONTINUOUS DUTY HIGHER CURRENT**
 - B. **CONTINUOUS DUTY PIN 5 OF THE IC IS EXTERNALLY CLOCKED**
2. **DATA SHEET CIRCUITS**
 - A. **LIGHT LOADS NEEDS 3 TO 4 WATTS**
 - B. **OVERSHOT**
 - C. **OPEN CIRCUIT**



REFERENCES

- (1) Jim Spangler, "A power factored corrected MOSFET, multiple output, flyback switching supply," Proceedings 10th PCIM '85 Conf. Oct 85, pp.19-32.
- (2) Jim Spangler, Bedruzzaman Hussain, Anup K Behera, "Electronic fluorescent ballast using power factor correction techniques for load greater than 300 watts" IEEE Proc. APEC 91, Dallas Tx, pp 393-399.
- (3) Jim Spangler, Anup K Behera, "Power factor correction techniques used for fluorescent lamp ballast" IEEE Proc. IAS 91, Dearborn, Mi, Sept 28-Oct 4, 91
- (4) Dave Pacholok, "Current sensing to boost converter efficiency", Powertechnics Aug. 1990, p.26-
- (5) Dave Pacholok, "Novel current sensing technique to boost converter efficiency", PCIM vol 14-5, July 1990

